



5-12m



18.500kg



43kN

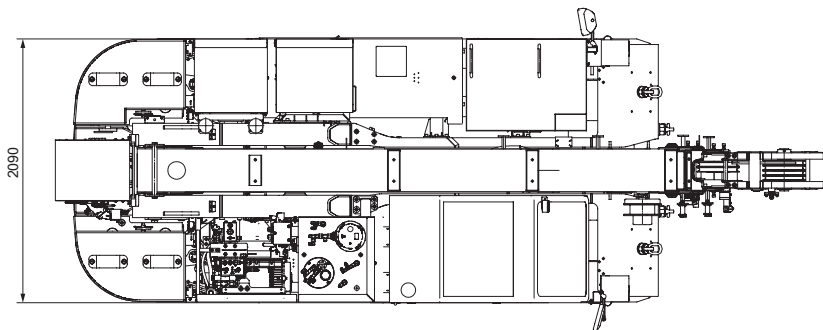
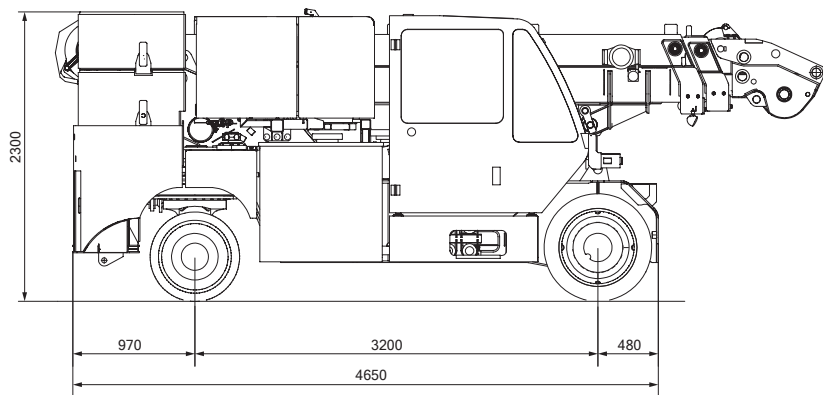



## Arbeitsbereiche am Hauptausleger

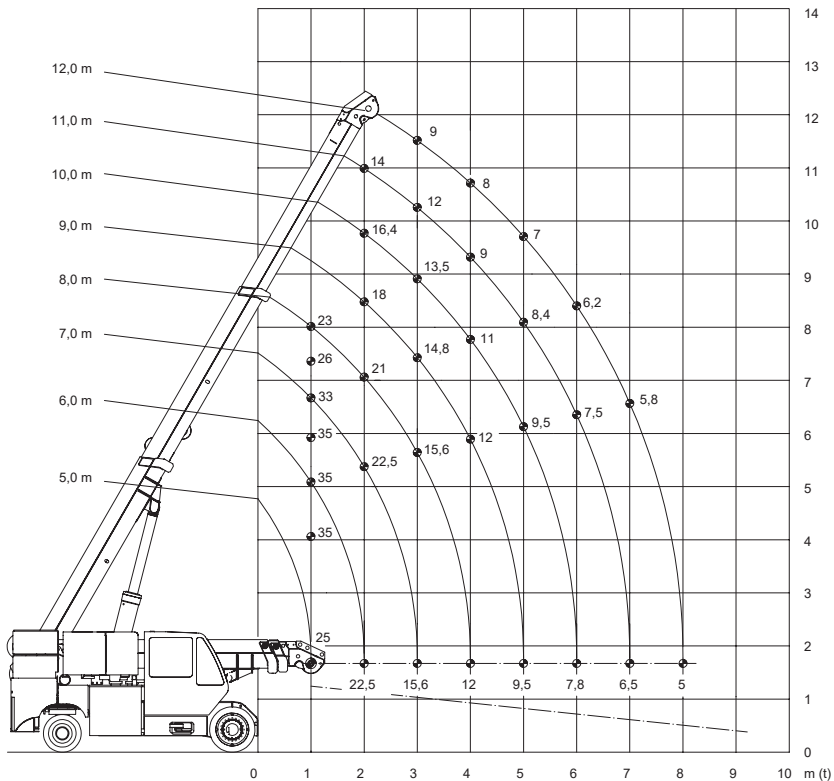



## Arbeitsbereiche mit Gabelträger

